

# **NovaSun**

**CENTRAL WATER HEATER SYSTEM**



**PRODUCT CATALOGUE**

## **INTRODUCTION**

**NOVASUN** one of the Global Solar Water Heating System Produce by PAPAEMNOUEL S.A Manufacture in Greece proposes sunny solutions, working with passion and devotion, for three decades now, to always offer the best.

We are one of the leading Greek companies in the manufacture of solar thermal products, having to our credit over 2,000,000 square meters of installed collectors worldwide. Our products are available either as OEM products for large international companies in more than 28 countries such as Greece, USA, Brazil, Mexico, Chile, Cyprus, Italy, Spain, Portugal, England, Germany, Hungary, Slovenia, Croatia, Albania, Bulgaria, Romania, Ukraine, Syria, Lebanon, Jordan, Malta, Morocco, Tunisia, United Arab Emirates, India, South Africa and other countries.

Our products have been installed to cover hot water needs without energy costs, both for domestic and professional applications (homes, hotel complexes, hospitals, sports centers, etc.).

We provide the following solutions:

Stand-alone solar panels with mounting brackets and hydraulic connections for large central systems. Complete Thermosiphon Solar Systems 120 up to and above 300 lt. Complete Solar Systems for Urgent Circulation up to and above 6000 lt. OEM components and parts of flat collectors (absorbers, fins etc.)

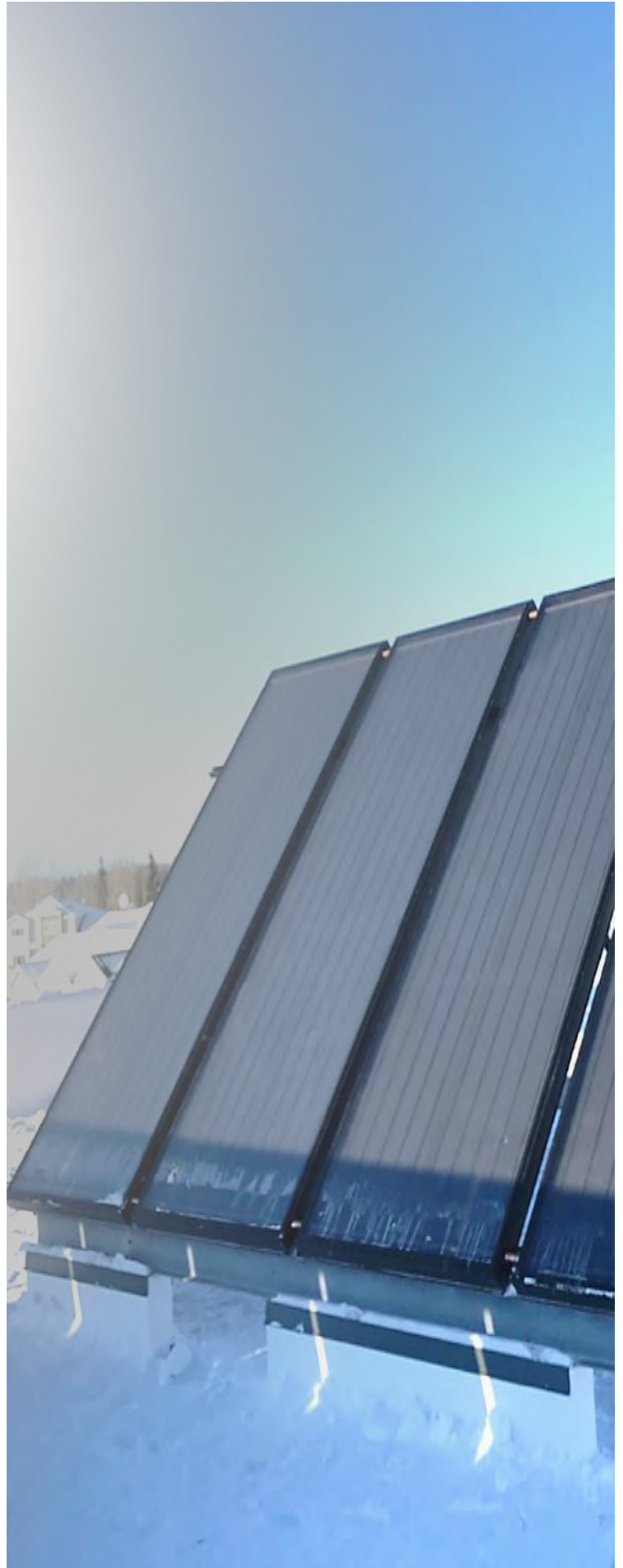

A solar system is Ecologically friendly, Economical, Simple, Aesthetic, Effective and Autonomous:

- **Ecologically friendly:**

with a NOVASUN system, the emissions of CO<sub>2</sub> avoided annually are equivalent to the fuel emissions of a car having run for 10.000 km.

- **Economical:**

will decrease your cost for energy by 70 -100% because the burner and electric resistance will not need to operate for at least 7-12 months of the year, depends on the sun radiation of each area and the size of the system.

- **Simple:**

The well-studied selection of materials of NOVASUN make its installation safe and easy, reducing the time needed for its installation to a minimum.

- **Aesthetic:**

The excellent exterior design of the NOVASUN collectors in combination with their well-studied support base, offer the possibility of a tangent installation on tiled roofs matching aesthetically with every architectural building design.

- **Effective and Autonomous:**

You have hot water at will 7-12 months per year. During winter time you secure the pre-heating of the water, and the extra hot water needed is secured from conventional energy.

Solar Water Heater

**The NOVASUN SOLAR WATER SYSTEM consists of**

All NOVASUN (storage tank, collector, support base and connection accessories), are delivered well packed to the customer.

The storage tank is placed between two round Styrofoam covers of 7 cm each, which are tightened on the storage tank with stretch film. Then it is placed in a hard carton pack, on which the indications of each model are displayed on the outside.

The collector is packed with 4 plastic protective elbows, attached on each corner, which are fast tightened around the collector with a plastic strap (upon special order, the collectors could be delivered in groups of 10 pcs on a wooden pallets).

All the parts of the support base, the plastic bag with the connection fittings, the thermal fluid and other accessories are packed in a carton box, on which the indications of each model appear on the outside.

The plastic bag contains all the connection fittings of each appliance like, screws, nuts for the support base, brackets, pipe unions, moly plugs, screw-nuts, safety valves, plugs and filling funnel of the thermal fluid.

All the tubes of the storage tank and collectors are covered with plastic plugs, in order to protect their turns from striking during the transportation.

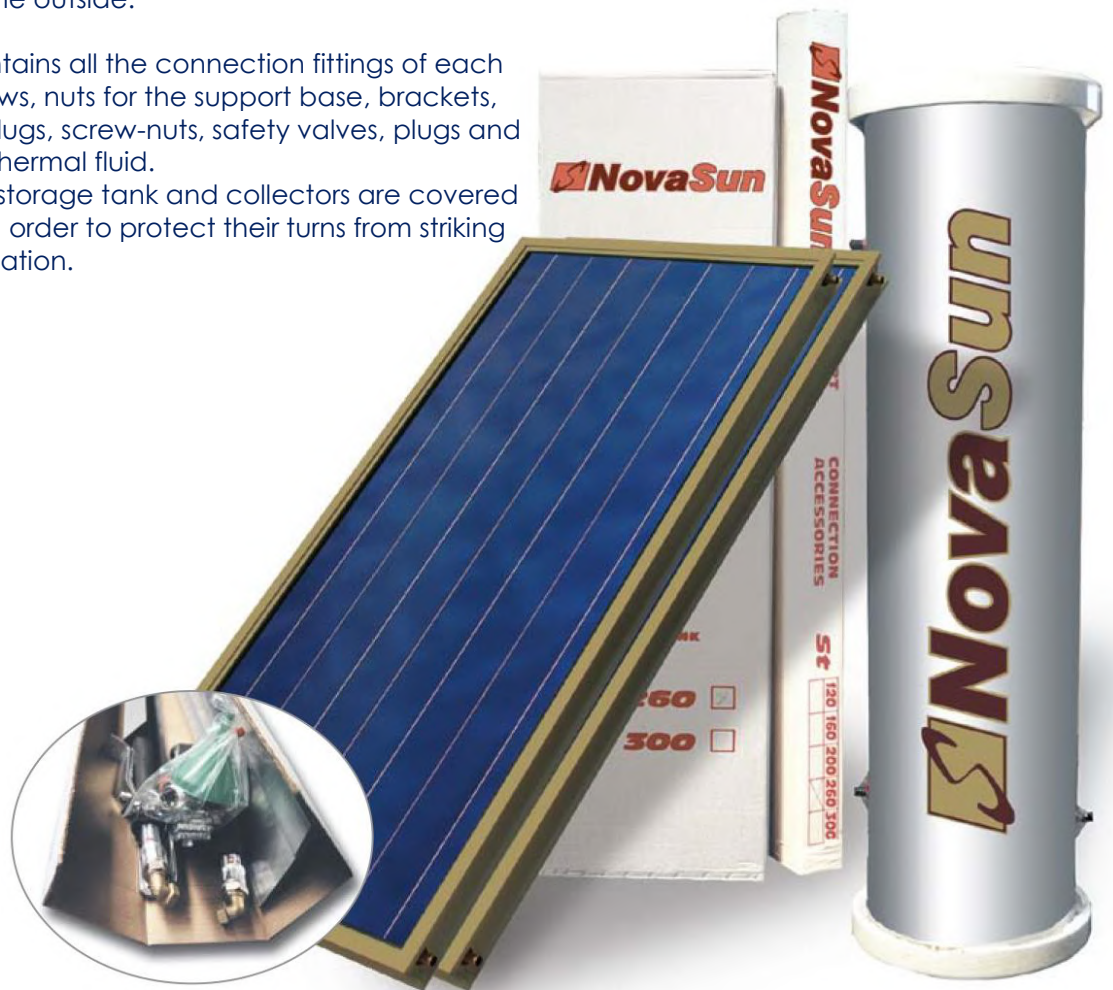

Reserves the right to change all specifications of the products and their accessories without prior notice.

# TECHNICAL SPECIFICATIONS OF THE COLLECTOR

## Description

Flat solar collector, firmly built, of new technology suitable for all forced circulation solar systems. The production process and the raw materials that are used produce a high thermal energy efficiency even during periods with insufficient radiation.

Absorber: a unique sheet of copper with selective titanium coating  
 Thermal Absorption: 95%  
 Thermal loss: 5%  
 Thickness: 0,2mm  
 Coating: selective titanium

## Characteristics of the tubes:

Diameter of the horizontal tubes: ( $\varnothing$  22mm)  
 Diameter of the vertical tubes: ( $\varnothing$  10mm or  $\varnothing$  8mm)  
 Material: copper  
 Test Pressure: 10 bars  
 Maximum functional pressure: 7 bars

## Frame:

Material: heavy aluminum profile  
 Back insulation: 35-40 mm insulation  
 Side insulation: 20 mm Rockwool

## Cover:

Material: solar tempered glass  
 Thickness: 3,5mm or 4mm  
 Water tightness: joint EPDM and transparent silicone

## General Characteristics:

Total thermal efficiency:  $95\% \pm 2\%$   
 Total thermal losses:  $5\% \pm 3\%$   
 Antifreeze: glycol appropriate for solar systems

## Panels

Model	Dimension (mm)	Gross Area (m <sup>2</sup> )	Operating Pressure (bar)	Weight (Kg) without water
NOVASUN150	1010x1480x86mm	1.50	10	28.20
NOVASUN182	1230x1480x86mm	1.82	10	33.20
NOVASUN200	1010x1980x86mm	2.00	10	36.60
NOVASUN237	1930x1230x86mm	2.37	10	43.00

Reserves the right to change all specifications of the products and their accessories without prior notice

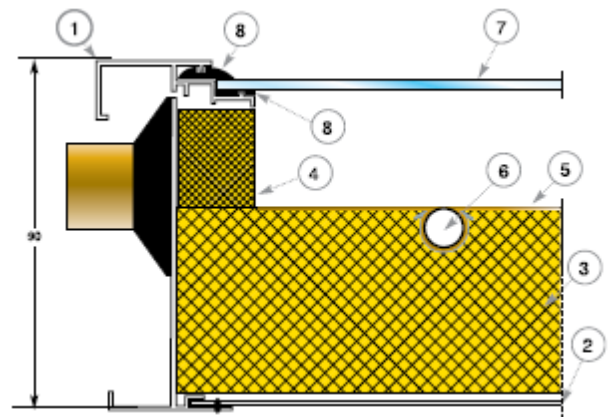

## Description

The NOVASUN boilers are manufactured according to European and German standards in the new state of the art solar boilers manufacturing facility and offer absolute safety in operation, great savings and a long lifespan. These tanks are for indoor use.



## THE STORAGE TANK NATURAL SYSTEM

- **External casing** : anodized aluminium
- **Tank's insulation** : polyurethane foam 40-55 mm
- **Cylinder's material** : galvanized sheeting 3mm
- **Jacket's material** : low carbon steel 1,5 mm
- **Cylinder's internal Protection** : durosmalt 80-120 microns
- **Additional protection** : magnesium rod
- **Electric resistance** : copper
- **Thermostat** : bipolar of four contacts
- **Power rate** : available from 0,8kW – 4kW

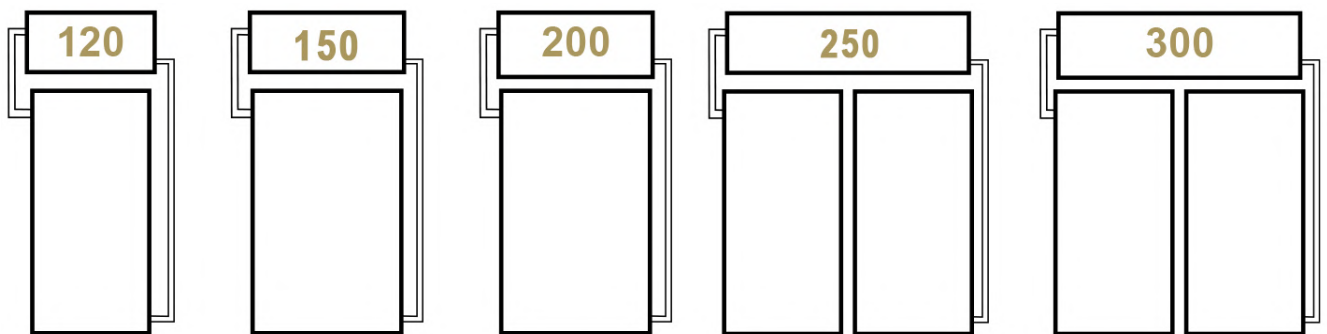
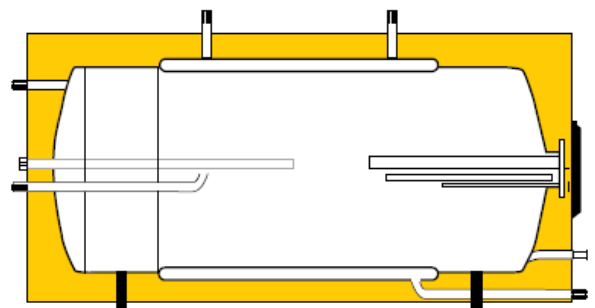

## Tank Range

Model	Dimension (mm)	Working Pressure (bar)	Max. Operating Pressure (bar)	Weight (Kg) without water
NSHW120	440x1000	7	10	52
NSHW150	510x1000	7	10	62
NSHW200	540x1100	7	10	70
NSHW250	570x1200	7	10	103
NSHW300	600x1300	7	10	114

Reserves the right to change all specifications of the products and their accessories without prior notice

# NOVASUN FORCED CIRCULATION SYSTEM

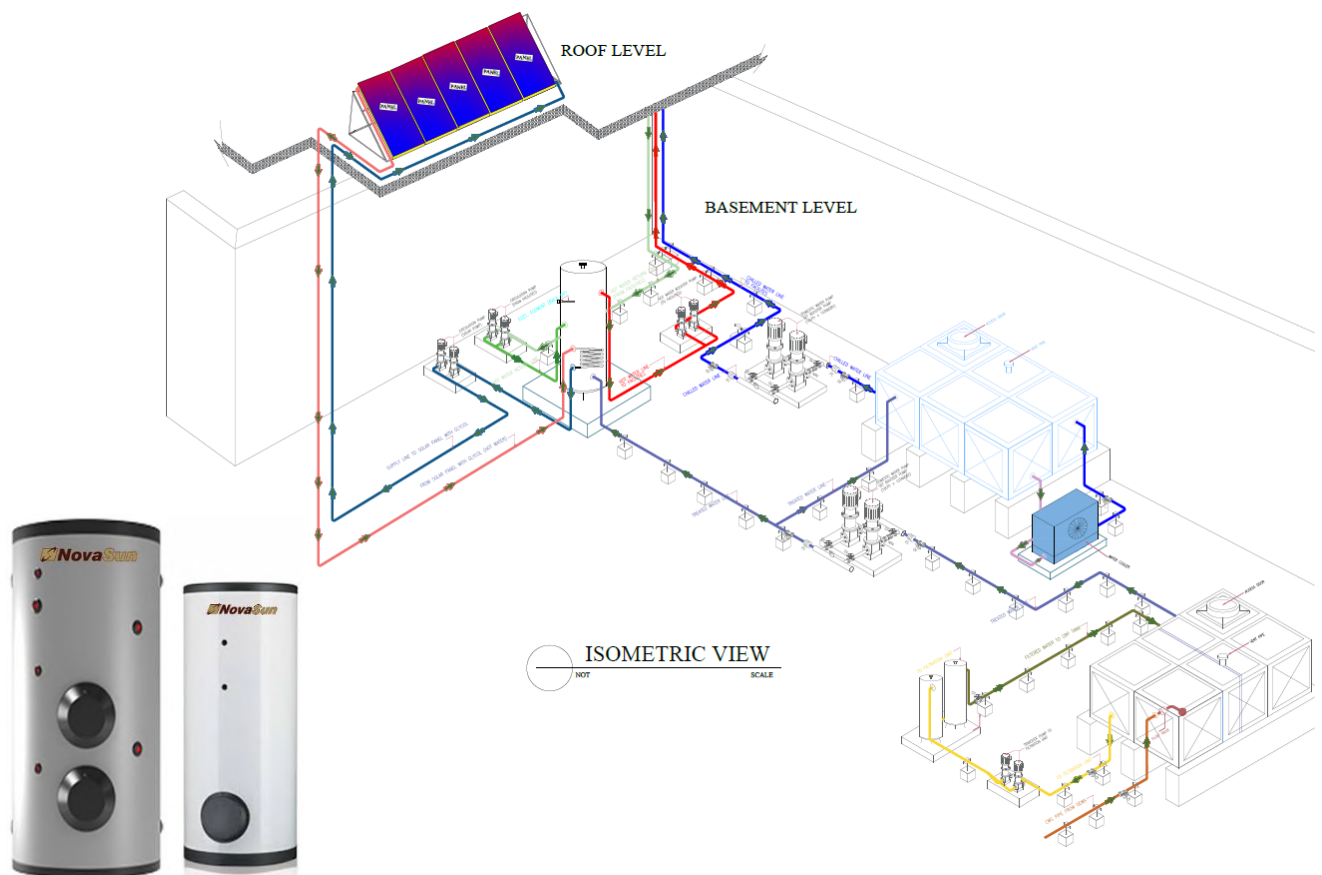

**GOING GREEN** Concept entails investing in renewable energy that do not harm the environment, are sustainable, and offer benefits in terms monetary savings on the long term is essential to productivity, enabling operations that have to do in the productions of goods and services. The choice of energy options is critical to the optimization of production lines. The choice is investing in an energy option that is sustainable and cost effective in the long run. Green energy is a term representing that offer a number of benefits including renewability, environmental and user friendly, high returns on investment that comes about because of savings in operational and maintenance inputs as well as income generation. Examples of green energies include solar.

# THE STORAGE TANK FORCED SYSTEM

## TECHNICAL DATA 1

**INNER TANK:** Stainless Steel 316L  
**ANODIC PROTECTION:** Magnesium Rod  
**MAX. WORKING PRESSURE:** 10 bar  
**MAX. WORKING TEMPERATURE:** 95°C  
**INSULATION:** High Density Polyurethane Foam 100mm, Density 52 Kg/m<sup>3</sup>  
**HEAT EXCHANGER:** Stainless Steel 316 L or Cooper Coil  
**HEAT EXCHANGER PRESSURE TEST:** 25 bar  
**WORKING PRESSURE OF THE EXCHANGER:** 16 bar  
**MAX. WORKING TEMPERATURE OF THE EXCHANGER:** 130°C  
**EXTERNAL COVERING:** Stainless Steel 304

## TECHNICAL DATA 2

**INNER TANK:** Steel Plate USD 37.2  
**INNER LINING:** Double Enamel Baked @ 850°C  
**MAX. WORKING PRESSURE:** 10 bar  
**MAX. WORKING TEMPERATURE:** 95°C  
**INSULATION:** High Density Polyurethane Foam 100mm, Density 52 Kg/m<sup>3</sup>  
**HEAT EXCHANGER:** Stainless Steel 316 L or Cooper Coil  
**HEAT EXCHANGER PRESSURE TEST:** 25 bar  
**WORKING PRESSURE OF THE EXCHANGER:** 16 bar  
**MAX. WORKING TEMPERATURE OF THE EXCHANGER:** 130°C  
**EXTERNAL COVERING:** G.I Painted Cover



Reserves the right to change all specifications of the products and their accessories without prior notice



# Tank with one Exchangeable Heat Exchanger

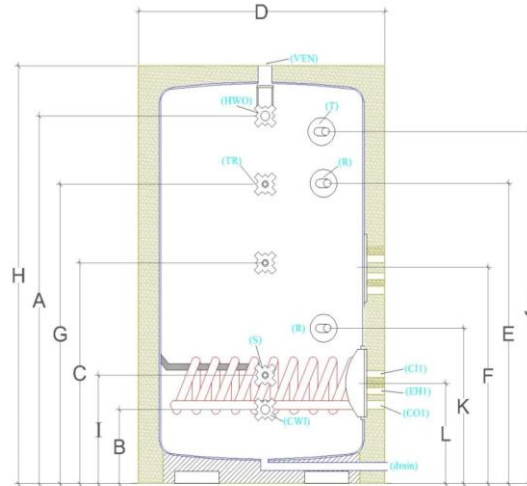

REFERENCE	NSWH 200F	NSWH 300F	NSWH 500F	NSWH 600F	NSWH 750F	NSWH 1000F
NOMINAL VOLUME (Lt)	200	300	500	600	750	1000
NET VOLUME (Lt)	196	296	495	580	730	980
FLANGE (Ø) mm	----	----	----	----	----	508
INNER TANK WEIGHT (Kg)	150	130	195	201	222	265
HEAT EXCHANGER WEIGHT (Kg)	75	78	78	78	78	109
EXTERNAL COVER WEIGHT (Kg)	5	9	10	11	11	20
INNER TANK BODY THICKNESS (mm)	2	2	2	2	2	5
TOP & BOTTOM CAPS OF INNER TANK THICKNESS	5	5	5	5	5	6
VENTELATION (VEN)	1"	1"	1 ½"	1 ½"	1 ½"	1 ½"
DRAIN	½"	½"	½"	½"	½"	½"
ELECTRICAL ELEMENT EH1/EH2	1 ½"	1 ½"	1 ½"	1 ½"	1 ½"	1 ½"
HEAT EXCHANGER C1/ C2	1"	1"	1"	1"	1"	1"
<b>A</b> HOT WATER OUTLET (HWO) mm	1 ½"	1 ½"	2"	2"	2"	2 ½"
<b>B</b> COLD WATER INLET (CW1) mm	1 ½"	1 ½"	2"	2"	2"	2 ½"
<b>C</b> SENSOR (S) mm	½"	½"	½"	½"	½"	½"
<b>D</b> EXTERNAL DIAMETER (mm)	560	660	660	750	850	950
<b>E</b> RECICULATION (R) mm	1 ½"	1 ½"	1 ½"	1 ½"	1 ½"	2"
<b>F</b> HEAT FLANGE (C2) mm	----	----	----	----	----	----
<b>G</b> THERMOMETER (TR) mm	½"	½"	½"	½"	½"	½"
<b>H</b> TOTAL HEIGHT (mm)	1300	1330	2090	2150	2240	2240
<b>I</b> SENSOR (S) mm	½"	½"	½"	½"	½"	½"
<b>J</b> THERMOSTAT (T) mm	½"	½"	½"	½"	½"	½"
<b>K</b> RECERCULATION (R) mm	1"	1"	1"	1"	1"	2"
<b>L</b> HEAT EXCHANGE FLANGE	----	----	----	----	----	565

Reserves the right to change all specifications of the products and their accessories without prior notice

# Tank with one Exchangeable Heat Exchanger

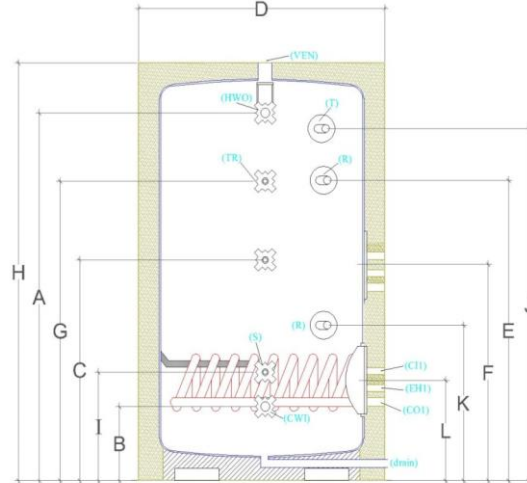

REFERENCE	NSWH 1500F	NSWH 2000F	NSWH 3000F	NSWH 4000F	NSWH 5000F	NSWH 6000F
NOMINAL VOLUME (Lt)	1500	2000	3000	4000	5000	6000
NET VOLUME (Lt)	1480	1940	2940	3950	4950	5950
FLANGE (Ø) mm	508	508	508	508	508	508
INNER TANK WEIGHT (Kg)	420	490	645	850	930	1080
HEAT EXCHANGER WEIGHT (Kg)	109	109	109	109	109	109
EXTERNAL COVER WEIGHT (Kg)	20	24	34	34	45	58
INNER TANK BODY THICKNESS (mm)	5	5	5	5	6	7
TOP & BOTTOM CAPS OF INNER TANK THICKNESS	6	6	6	5	7	8
VENTELATION (VEN)	1 ½"	1 ½"	1 ½"	1 ½"	1 ½"	1 ½"
DRAIN	½"	½"	½"	½"	½"	½"
ELECTRICAL ELEMENT EH1/EH2	1 ½"	1 ½"	1 ½"	1 ½"	1 ½"	1 ½"
HEAT EXCHANGER C1/ C2	1"	1"	1"	1"	1"	1"
<b>A</b> HOT WATER OUTLET (HWO) mm	2 ½"	2"	2 ½"	3"	3"	4"
<b>B</b> COLD WATER INLET (CW1) mm	2 ½"	2"	2 ½"	3"	3"	4"
<b>C</b> SENSOR (S) mm	½"	½"	½"	½"	½"	½"
<b>D</b> EXTERNAL DIAMETER (mm)	1200	1200	1350	1650	1800	1900
<b>E</b> RECICULATION (R) mm	2"	2 ½ "	2 ½"	3"	3"	3 "
<b>F</b> HEAT FLANGE (C2) mm	400	----	----	----	----	----
<b>G</b> THERMOMETER (TR) mm	½"	½"	½"	½"	½"	½"
<b>H</b> TOTAL HEIGHT (mm)	1960	2360	2400	2500	2570	2600
<b>I</b> SENSOR (S) mm	½"	½"	½"	½"	½"	½"
<b>J</b> THERMOSTAT (T) mm	½"	½"	½"	½"	½"	½"
<b>K</b> RECERCULATION (R) mm	2"	2"	2 ½"	3"	3"	3"
<b>L</b> HEAT EXCHANGE FLANGE	565	565	565	565	565	593

Reserves the right to change all specifications of the products and their accessories without prior notice

# Tank with Two Exchangeable Heat Exchanger

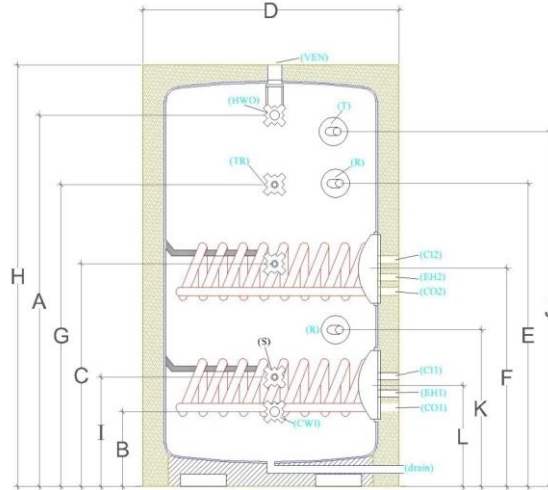

REFERENCE	NSWH 200F	NSWH 300F	NSWH 500F	NSWH 600F	NSWH 750F	NSWH 1000F
NOMINAL VOLUME (Lt)	200	300	500	600	750	1000
NET VOLUME (Lt)	196	296	495	580	730	980
FLANGE (Ø) mm	----	----	----	----	----	508
INNER TANK WEIGHT (Kg)	150	130	195	201	222	265
HEAT EXCHANGER WEIGHT (Kg)	75	78	78	78	78	109
EXTERNAL COVER WEIGHT (Kg)	5	9	10	11	11	20
INNER TANK BODY THICKNESS (mm)	2	2	2	2	2	5
TOP & BOTTOM CAPS OF INNER TANK THICKNESS	5	5	5	5	5	6
VENTELATION (VEN)	1"	1"	1 ½"	1 ½"	1 ½"	1 ½"
DRAIN	½"	½"	½"	½"	½"	½"
ELECTRICAL ELEMENT EH1/EH2	1 ½"	1 ½"	1 ½"	1 ½"	1 ½"	1 ½"
HEAT EXCHANGER C1/ C2	1"	1"	1"	1"	1"	1"
<b>A</b> HOT WATER OUTLET (HWO) mm	1 ½"	1 ½"	2"	2"	2"	2 ½"
<b>B</b> COLD WATER INLET (CW1) mm	1 ½"	1 ½"	2"	2"	2"	2 ½"
<b>C</b> SENSOR (S) mm	½"	½"	½"	½"	½"	½"
<b>D</b> EXTERNAL DIAMETER (mm)	560	660	660	750	850	950
<b>E</b> RECICULATION (R) mm	1 ½"	1 ½"	1 ½"	1 ½"	1 ½"	2"
<b>F</b> HEAT FLANGE (C2) mm	----	----	----	----	----	----
<b>G</b> THERMOMETER (TR) mm	½"	½"	½"	½"	½"	½"
<b>H</b> TOTAL HEIGHT (mm)	1300	1330	2090	2150	2240	2240
<b>I</b> SENSOR (S) mm	½"	½"	½"	½"	½"	½"
<b>J</b> THERMOSTAT (T) mm	½"	½"	½"	½"	½"	½"
<b>K</b> RECERCULATION (R) mm	1"	1"	1"	1"	1"	2"
<b>L</b> HEAT EXCHANGE FLANGE	----	----	----	----	----	565

Reserves the right to change all specifications of the products and their accessories without prior notice

## Tank with Two Exchangeable Heat Exchanger

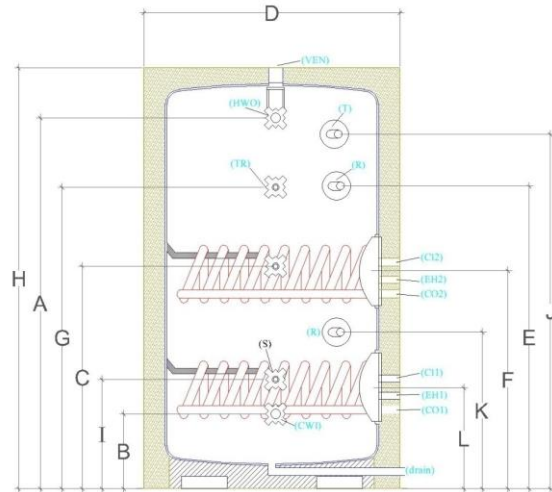

REFERENCE	NSWH 1500F	NSWH 2000F	NSWH 3000F	NSWH 4000F	NSWH 5000F	NSWH 6000F
NOMINAL VOLUME (Lt)	1500	2000	3000	4000	5000	6000
NET VOLUME (Lt)	1480	1940	2940	3950	4950	5950
FLANGE (Ø) mm	508	508	508	508	508	508
INNER TANK WEIGHT (Kg)	420	490	645	850	930	1080
HEAT EXCHANGER WEIGHT (Kg)	109	109	109	109	109	109
EXTERNAL COVER WEIGHT (Kg)	20	24	34	34	45	58
INNER TANK BODY THICKNESS (mm)	5	5	5	5	6	7
TOP & BOTTOM CAPS OF INNER TANK THICKNESS	6	6	6	5	7	8
VENTELATION (VEN)	1 ½"	1 ½"	1 ½"	1 ½"	1 ½"	1 ½"
DRAIN	½"	½"	½"	½"	½"	½"
ELECTRICAL ELEMENT EH1/EH2	1 ½"	1 ½"	1 ½"	1 ½"	1 ½"	1 ½"
HEAT EXCHANGER C1/ C2	1"	1"	1"	1"	1"	1"
A HOT WATER OUTLET (HWO) mm	2 ½"	2"	2 ½"	3"	3"	4"
B COLD WATER INLET (CW1) mm	2 ½"	2"	2 ½"	3"	3"	4"
C SENSOR (S) mm	½"	½"	½"	½"	½"	½"
D EXTERNAL DIAMETER (mm)	1200	1200	1350	1650	1800	1900
E RECIRCULATION (R) mm	2"	2 ½"	2 ½"	3"	3"	3"
F HEAT FLANGE (C2) mm	400	----	----	----	----	----
G THERMOMETER (TR) mm	½"	½"	½"	½"	½"	½"
H TOTAL HEIGHT (mm)	1960	2360	2400	2500	2570	2600
I SENSOR (S) mm	½"	½"	½"	½"	½"	½"
J THERMOSTAT (T) mm	½"	½"	½"	½"	½"	½"
K RECIRCULATION (R) mm	2"	2"	2 ½"	3"	3"	3"
L HEAT EXCHANGE FLANGE	565	565	565	565	565	593

Reserves the right to change all specifications of the products and their accessories without prior notice

# VERTICAL BUFFER TANKS WITHOUT HEAT EXCHANGER

MODEL	DIMENSION		REFERENCE
	DIAMETER (mm)	HEIGHT (mm)	BUFFER TANKS
300	660	1330	COS DA0 300
500	660	2090	COS DA0 500
750	850	2240	COS DA0 750
1000	950	2240	COS DA0 1000
1500	1200	1960	COS DA0 1500
2000	1200	2360	COS DA0 2000
3000	1350	2600	COS DA0 3000
4000	1720	2200	COS DA0 4000
5000	1920	2200	COS DA0 5000
6000	2100	2200	COS DA0 6000

## TECHNICAL DATA 1

**INNER TANK:** Stainless Steel 316L

**ANODIC PROTECTION:** Magnesium Rod

**WORKING PRESSURE OF THE BUFFER TANK:** 8 bar

**MAX. WORKING PRESSURE:** 10 bar

**MAX. WORKING TEMPERATURE:** 95°C

**INSULATION:** High Density Polyurethane Foam 40Kg/m<sup>3</sup>

**SIDE FLANGE:** Ø600mm

**EXTERNAL COVERING:** Stainless Steel 304

## TECHNICAL DATA 2

**INNER TANK:** Steel Plate USD 37.2

**ANODIC PROTECTION:** Magnesium Rod

**WORKING PRESSURE OF THE BUFFER TANK:** 8 bar

**MAX. WORKING PRESSURE:** 10 bar

**MAX. WORKING TEMPERATURE:** 95°C

**INSULATION:** High Density Polyurethane Foam 40Kg/m<sup>3</sup>

**SIDE FLANGE:** Ø600mm

**EXTERNAL COVERING:** G.I Painted Cover



Reserves the right to change all specifications of the products and their accessories without prior notice

# VERTICAL BUFFER TANKS WITHOUT HEAT EXCHANGER

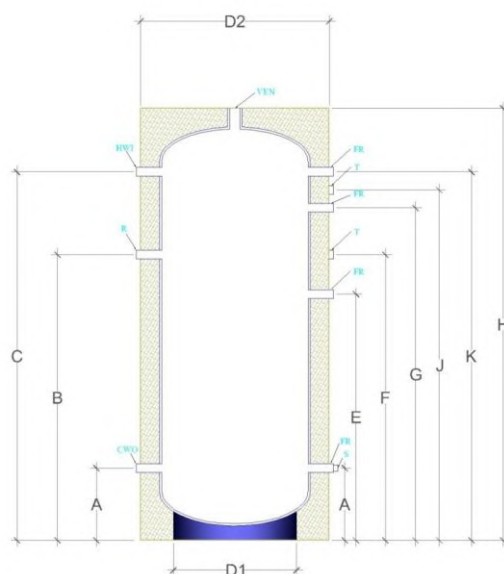

## TECHNICAL CHARACTERISTIC (COS DA0 300-1500 LITER)

REFERENCE	COS DA0 300	COS DA0 500	COS DA0 750	COS DA0 1000	COS DA0 1500
NOMINAL VOLUME (Lt)	300	500	750	1000	1500
NET VOLUME (Lt)	296	492	746	882	1539
INNER TANK THICNESS (mm)	2.5	3	3	3	4
BUFFER TANK WEIGHT (Kg)	56.7	84.50	117	132.80	267
VENTELATION (VEN)	1"	1"	1"	1"	1"
OUTLET TOWARDS BURNER CWO (mm)	1"	1"	1"	1"	3"
A SENSOR (S)	1/2"	1/2"	1/2"	1/2"	1/2"
FREE OUTLET FR	1"	1"	1"	1"	3"
B RE CIRCULATION R	1'	1"	1"	1"	3"
C RETURN INLET FROM BURNER HWI (mm)	1"	1"	1"	1"	3"
D1 DIAMETER OF THE TANKS STANDS (mm)	600	660	750	850	950
D2 EXTERNAL DIAMETER OF THE TANK (mm)	660	660	850	950	1200
E FREE OUTLET	1"	1"	1"	1"	3"
F THERMOSTAT	1/2'	1/2"	1/2"	1/2'	1 1/2"
G FREE OUTLET FR (mm)	1"	1"	1"	1"	3"
H TOTAL HEIGHT (mm)	1580	1880	2000	2040	2100
THERMOMETER TR	1/2"	1/2"	1/2"	1/2"	1/2"
K FREE OUTLET FR (mm)	1"	1"	1"	1"	3"

Reserves the right to change all specifications of the products and their accessories without prior notice

Note: Buffer Tanks can be equipped with and electrical element

# VERTICAL BUFFER TANKS WITHOUT HEAT EXCHANGER

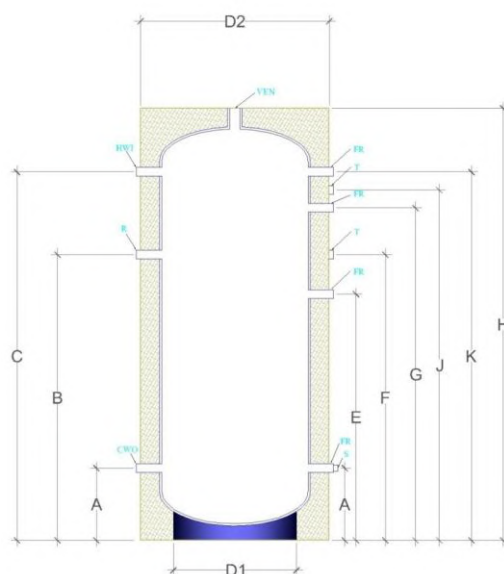

## TECHNICAL CHARACTERISTIC (COS DA0 2000-6000 LITER)

REFERENCE	COS DA0 2000	COS DA0 3000	COS DA0 4000	COS DA0 5000	COS DA0 6000
NOMINAL VOLUME (Lt)	2000	3000	4000	5000	6000
NET VOLUME (Lt)	1960	2960	3960	4950	5960
INNER TANK THICKNESS (mm)	4	5	5	6	7
BUFFER TANK WEIGHT (Kg)	490	585	695	876	1015
VENTELATION (VEN)	1 ½"	1 ½"	1 ½"	1 ½"	1 ½"
OUTLET TOWARDS BURNER CWO (mm)	2 ½"	2 ½"	3"	3"	4"
A SENSOR (S)	½"	½"	½"	½"	½"
FREE OUTLET FR	3"	3"	3"	3"	4"
B RE CIRCULATION R	½"	½"	½"	½"	½"
C RETURN INLET FROM BURNER HWI (mm)	3"	3"	3"	3"	4"
D1 DIAMETER OF THE TANKS STANDS (mm)	1100	1250	1550	1700	1800
D2 EXTERNAL DIAMETER OF THE TANK (mm)	1200	1350	1650	1800	1900
E FREE OUTLET	3"	3"	3"	4"	4"
F THERMOSTAT	1"	1"	3"	3"	3"
G FREE OUTLET FR (mm)	3"	3"	3"	4"	4"
H TOTAL HEIGHT (mm)	2360	2400	2500	2570	2600
THERMOMETER TR	½"	½"	½"	½"	½"
K FREE OUTLET FR (mm)	3"	3"	3"	4"	4"

Reserves the right to change all specifications of the products and their accessories without prior notice

Note: Buffer Tanks can be equipped with and electrical element

## DIFFERENTIAL THERMOSTAT

### Description

The programmable electronic thermostat secures the smooth transfer of thermal energy from solar collectors to the boilers via an electronic command to the circulator of the solar system.

### Function

The differential thermostat continuously checks the difference in temperature between the boiler and the solar collectors. In the case where the temperature of the collectors is up to 10°C higher (recommended adjustment 4-6°C) than the temperature of the boiler, the differential thermostat starts up the pump of the solar system.

This temperature along with the corresponding adjustment to the thermostat is named «starting differential temperature». The circulator will stop when the difference of temperature between the collectors and the boiler is below 2°C (according to the suggested adjustment rate). In case solar energy is not sufficient, the transferable contact SPDT of the differential thermostat for the startup of a backup source of energy (heat pumps, central heating system) can be used.

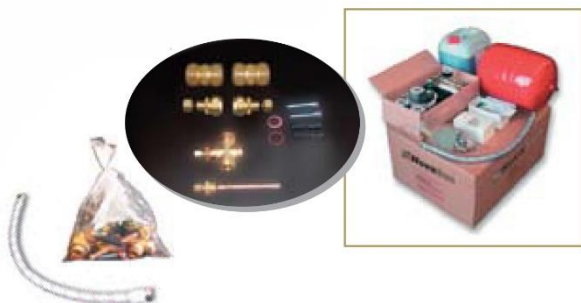

## Connection Accessories

All of the necessary connection accessories of each unit are located in an incorporated packaging which consists of the following:

- Screws, bolts, nuts, moly plugs, etc.
- Bronze cross
- Connection records of collectors and plugs
- Flexible tube for the expansion pot
- Sensor-socket (boiler-collectors)
- Degasser of the collectors

## Expansion Vessel

The expansion pot of 18 – 3,000 liters is suitable for all of the systems (120Ltr up to 6,000 Liter) and It is connected to the hydraulic kit with the flexible tube which is included in the package.





## Antifreeze Liquid



<b>Dilution</b>	
% Vol. in Water	Freezing Point
20%	-7°C
30%	-13°C
40%	-23°C
50%	-34°C

Glycol is used to avoid the freezing of the thermal liquid of the solar collectors of the closed circuit. It is delivered in a plastic bottle of 10 liters. It must be mixed with water depending on the weather conditions (minimal environmental temperature) in the area where the solar system is installed. The table on the left shows the analogy of Water / Glycol to the environmental temperature.

## Electric Resistance

The existence of a backup energy source secures the availability of hot water in the cases of low sunshine and /or in availability of other back up energy source (central heating system or heat pump).

### Technical Characteristics of the electric resistance:

**Material:** Copper or Stainless Steel

**Power:** 2 or 4 kW (1~230 V)

6 to Higher kW (3~400 V) as per the required Capacity



## Thermostat

All of the single-phase electric resistances are delivered with a thermostat with a uni-polar interruption function as well as a bi-polar interruption thermal safety button with manual reset.



## Magnesium Anode

Prevents electrolytic corrosion, which in turn gives the tank a longer life.

## HYDRAULIC KIT

- |                                     |  |  |
|-------------------------------------|--|--|
| 1) Circulation pump                 | 5) Pressure gage   | 9) Safety valve                            |
| 2) SETTER Inline UN balancing valve | 6) Thermometer   | 10) Connector ADG for the expansion vessel |
| 3) Venting tank with bleeder valve  | 7) Stop ball valve with safety valve                     | 11) Wall fixing                            |
| 4) Bleeder valve                    | 8) Stop ball valve with fill and drain cock & integrated | 12) Packaging box                          |



Reserves the right to change all specifications of the products and their accessories without prior notice

## Application

As a pump, regulator and air venting valve in solar heating systems. With the hydraulic kit, hydraulic balancing, flow measurement and venting can be performed directly in the station.

The built-in SETTER Inline UN allows the required quantity of fluid in the primary circuit to be exactly and simply set and checked. The continuous venting system meets the most demanding requirements and keeps the system free of air.

Systems which are correctly balanced hydraulically and air-free guarantee optimal energy extraction, and are thus more cost-effective in the sense of the energy-saving directives laid down by law. Using the scale, which is pre-calibrated for glycol, the technician can set and check the exact flow-rate values on-site. Neither training courses nor expensive measuring devices are required. Installation and venting can be carried out by one person working unaided.

## Installation position

The solar station must be mounted vertically to ensure problem-free functioning of the venting unit.

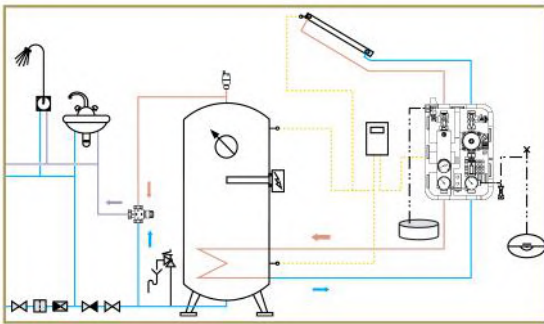

## Advantages

- Cost-effective installation and filling
- Multi-functional ball valve, which greatly simplifies the filling and draining of the system
- Collector and reservoir sections can be separated for installation work
- Straightforward pump replacement (suction and pressure side can be shut off)
- Precise and rapid regulation adjustments, requiring no diagrams, tables or expensive measuring devices
- Function checking using the direct flow rate indicator in the SETTER Inline UN
- Visual scale in l/min pre-calibrated for glycol mixes  $\nu=2.3\text{mm}^2/\text{s}$
- Constant air release while system is running
- Straightforward venting directly in the station
- Can be connected to any readily-available controller
- Reliable operation, and maintenance-free
- Rugged design

## Operation

The flow-rate measurement is based on the proven principle of a baffle float.

The basis for the air venting are special flow technology measures which accumulate the air in the top of the venting space, from where it can be released from time to time. At the same time, acts as a check on whether air is building up in the system. There are no mechanical parts, so the design ensures a long service life.

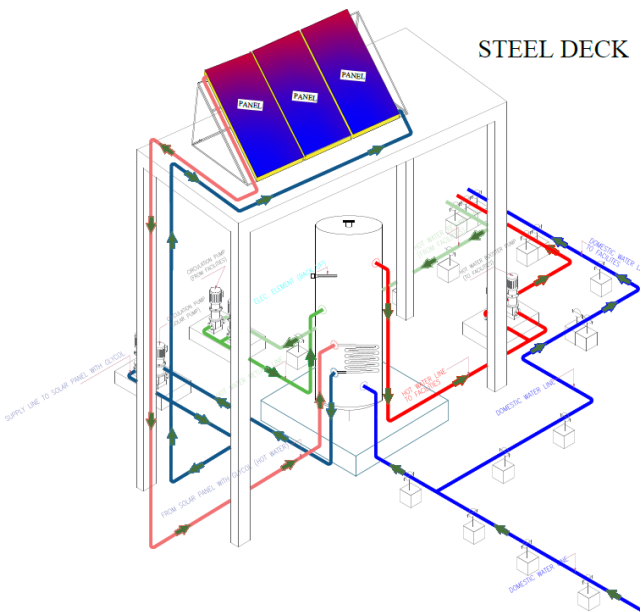

Reserves the right to change all specifications of the products and their accessories without prior notice

## **General Information on needs of hot water**

### **General Information**

When choosing a solar system for hot water we must first determine our needs for hot water, in quantity as well as in preferred temperature of consumption. The typical calculation for the temperature for consumption is 45°C, but for the calculation of required quantity you must take into account the daily needs.

Calculation of needs for hot water usage

### **1) RESIDENCES**

In family residences, the needs for hot water remain stable during the whole year. An indication

for the needs is given by the number of individuals living in the building (or apartment). Usually, the per capita daily consumption of hot water at 45°C is calculated taking into consideration the following:

Low consumption: 35 liters per capita / day

Medium consumption: 60 liters per capita / day

High consumption: 80 liters per capita / day

In the case where we want to connect to the solar installation the washing machine and the dishwasher, we would have to increase the calculated daily needs of consumption as follows:

Washing Machine: 20 liters / day (1 wash per day)

Dishwasher: 20 liters / day (1 wash per day)

#### **Example:**

A family of 4 persons needs around 240 liters of hot water daily in order to have a medium daily consumption. (60 liters per capita x 4 persons). If we include a washing machine and dishwasher, then we must calculate a consumption of 280 liters per day.

### **2) HOTELS – HOSTELS**

In buildings such as hotels, hostels, etc..., the needs for hot water are related to the amount of customers. In this case the daily consumption is calculated by the average occupancy of the rooms, from the period of May up until August. Using this basis, the size of the proposed installation is determined. Here below we indicate the per capita daily need for hot water at 45°C

Hostels with rooms with shared bath: 35 liters / person / day

Hostels: 40 liters / person / day

2 Star Hotels: 50 liters / person / day

3 Star Hotels: 80 liters / person / day

4 Star Hotels: 100 liters / person / day

Camping: 60 liters / person / day

## **General Information on needs of hot water**

### **Example:**

An installation of agro tourism is maintained by a family of 4 persons, that live in the residence. During the period between May and August the average occupancy is 15 clients per day. For the occupants 2 meals are prepared per day and the dishwasher washes 5 times per day.

Needs of family:  $4 \times 60 \text{ lt} = 240 \text{ litres / day}$

Needs of the clients :  $15 \times 50 \text{ lt} = 750 \text{ litres / day}$

Kitchen:  $30 \times 10 \text{ lt} = 300 \text{ litres / day}$

Dishwasher:  $5 \times 20 \text{ lt} = 100 \text{ litres / day}$

Total: 1.390 litres / day

### **3) OTHER APPLICATIONS**

We present the daily consumption for other applications:

*Hospitals and clinics* : 80 litres / bed

*University residences*: 80 litres / bed

*Dressing rooms, public showers*: 20 litres / person

*Schools*: 5 litres / student

*Restaurants* : 8 to 15 litres / meal

*Bars*: 2 litres / client

*Prisons*: 30 litres / person

*Factories* : 20 litres / persona

*Offices* : 5 litres / employee

*Gymnasiums* : 30 litres / user

The information of the above table can also be used in combinations so that in every case the average daily consumption can be properly calculated.

### **FACTORS OF INCREASED NEEDS**

In the case that a recirculation system exists for the hot water usage, you will also have to take this into account for the needs. The calculation will have to be made every time individually from the above tables and depends on the dimensions of the circuit and it's thermal insulation. Additionally, in the determination of the total needs, the thermal losses of the total distribution circuit from the point of storage to the points of final consumption must be taken into consideration.

### **REAL NEEDS**

In every case, the real needs for hot water are related to the personal attitude, the possible special characteristics and habits of every place and application and also the way each application functions.

For this reason, a specific calculation can be made by using the information on the gas/ petrol or electric bill. A flow meter installed on the hot water pipes could also be used.

# INSTALLATION INSTRUCTIONS

1. Before you start installing the solar water heater, please read carefully all the installation instructions stated and illustrated in this manual.
2. Before the installation of the solar water heater, it is very important that the customer and the installer agree on all the details concerning the correct and safe installation of the appliance, (such as location, placement point, static resistance and control of the surface on which the appliance will be placed, piping and wiring run etc).
3. The installation should be done according to the local electric and plumbing regulations.
4. The location you will choose for the installation of the solar collector(s) should not be shaded by any obstacles (trees, buildings...etc.) all around the year. (see obstacle table here below).
5. For optimum performance of the solar system, the collector(s) must face South, for countries located in the Northern hemisphere and North for countries located in the Southern hemisphere. In case that it is not totally possible for the solar collector(s) to face the equator, you must turn it (them) towards East up to 30° if major hot water draw is before 14:00 p.m., or towards West up to 30° if major hot water draw is after 14:00 p.m.

The ideal inclination of the solar collector(s) should be equal to the latitude in which the installation is done.

6. The support base of the collector(s) is the same for both flat and inclined roofs. It is diversified only in the way of it's assembly.
7. If the surface on which the solar collector(s) will be installed (inclined or flat) is not compatible with the standard equipment supplied with each appliance, then alternate equipment must be used.

The installer has to choose, propose and install this alternate equipment, always under the concurrent opinion of the customer.

8. For installation on an inclined roof, the «D» plates must be screwed with the appropriate screws and nuts on the roof timber, in order to secure the right and safe installation of the collector(s).

9. In regions subject to heavy snowfalls, rainfall, storms, strong winds, cyclones, tornadoes it is very important to ensure that the supports of the standard equipment is sufficient to withstand the weight of the expected snow or the intensity of the weather conditions. In these cases, the collector(s) must be placed in a stable way on the roof and must be tightened with additional metal straps.

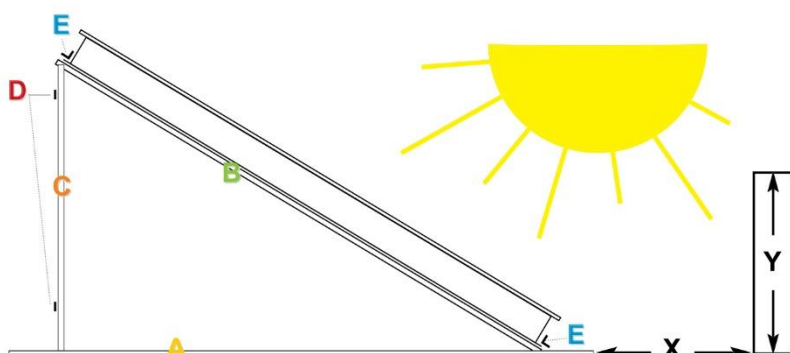

Latitude	Distance between collector and obstacle
0°- 25°	$X = 1,0 \times Y$
25°- 35°	$X = 1,5 \times Y$
35°- 45°	$X = 2,0 \times Y$
45°- 50°	$X = 2,5 \times Y$
50° +	$X = 3,0 \times Y$

Instructions to the customer and installer

In the case of the malfunction of the system and before contacting the installer, distributor or agent, please have at hand the information on the next page.

### **INSTRUCTIONS OF USE – RECOMMENDATIONS**

- The NOVASUN solar systems do not require the intervention of the user. It is recommended though, that after the first 15 days of functioning, to check the pressure of the closed circuit (collector - boiler) and that the temperatures are at normal levels in relation with the time of the inspection, the sunlight and the «Installation Sheet».
- After two years of functioning, it is recommended that a program of annual service is begun.
- If there is a breakage of collector's glass, it must be replaced immediately so that the absorber will not be damaged.
- If there is a lot of dust in the area, then the glass of the collectors will have to be washed at least twice a year with water, except if it often rains.
- After the installation is complete, the installer will have to inform the client about the functioning of the system.

In the case of any malfunction of the system, we recommend the client to contact the installer since he only knows all of the various parameters and the possible particular characteristics of the installation.

### **IN THE CASE OF MALFUNCTION (Instructions to the installer)**

Ensure that:

- The climate conditions permit the functioning of the solar system.
- There is no shading of the collectors by any obstacles and that they are clean from dust.
- That there is no leakage in the closed circuit and that all of the connections, records, and pipes are tightly screwed and water-tight.
- That the function of the circulator is correctly programmed. In the case of CAMPINI, the starting differential temperature is programmed by the producer at 10°C above the temperature of the boiler (6°C is recommended). Refer to the «Installation Sheet» since the installer might have changed this parameter.
- The circulator is functioning if the weather conditions allow for it's function. By touching the circulator we can feel the vibrations of the system. Check the electric current on the electric board and if needed contact the electrician of the installation.
- The mixing valve for hot / cold water in the outlet of the boiler is correctly adjusted and is functioning.
- The pressure of the closed circuit (indication of the manometer on the hydraulic kit) is the same, with the one described on the «Installation Sheet» (around 1.5 – 2.5 bar). If you can, for the immediate function of the system, fill it with antifreeze liquid and water from the water supply or properly adjust the automatic filling, up to the pressure indicated on the «Installation Sheet».
- That there is enough liquid in the closed circuit of collectors-boiler. In days with intense sunlight and normal function of the circulator, the highest points of the pipes must be warm, (for example - top outlet of the collector). Be careful to the false warmth which might be caused from the direct sunlight
- There is gas in the expansion pot (if needed check for pre-pressure air only with empty installation as stated on the «Installation Sheet»), and that the safety valve has not opened.

**Note:** All the connections and the installations must be done according to the regulations (electrical, plumbing, urbanism and others) that apply in your area.

## TROUBLESHOOTING CHECK LIST

Ref	List	TESTING		Comment
		YES	NO	
<b>Collectors and External Piping</b>				
1	Is the installation and fixing of the support base according to the instructions and local regulations?			
2	Is there an idea l location and facing of the collectors?			
3	UV protection on the thermal insulation?			
4	Has there been good insulation of all the piping?			
<b>Primary Circuit (Solar)</b>				
5	Does the closed circuit have the right pressure?			
6	Are there any leaks in the closed circuit, the connections, or in the tube heat exchanger?			
7	Is there a safety valve connected?			
8	Does the Circulation Pump Functioning well?			
	If No. does it need replacement?			
<b>Thermal Fluid</b>				
9	The thermal fluid mixed well with water?			
10	Filled the mixture fluid to the filling valve.			
11	Make sure that no air is trapped inside the storage tank and collector.			
<b>Differential Thermostat – Electric Connections</b>				
12	Are the electric cables properly fixed?			
13	Has the electric connection been done according to the local regulations?			
<b>Solar Water Tank and Hot Water Circuit</b>				
14	Does a mixing valve exist?			
	If yes does hot / cold water exist?			
15	Is the insulation of the <b>Solar Water Tank</b> in good condition?			
<b>if Required Thermal Tank (Pre Heating System)</b>				
16	Is the insulation of the <b>Thermal Tank</b> in good condition?			
17	Does the Circulation Pump between Thermal Tank and Solar Tank Functioning well?			
	If No. does it need replacement?			
<b>If Required Secondary Circulation Pump (Return Line)</b>				
18	Does the Circulation Pump Functioning well?			
	If No. does it need replacement?			



PAPAEMMANOUEL SA  
1st mill. Oinophyton Agios Thomas,  
Oinophyton Industrial Area,  
32011, Inofyta Boeotia  
[www.papaemmanouel.gr](http://www.papaemmanouel.gr)  
Contact us on: +30 22620 31931



Enviroenergy Solutions E.S. Ltd.  
10<sup>th</sup> dervi str. – 1305 Nicosia – Cypros  
[www.enviroenergysolutions.com](http://www.enviroenergysolutions.com)  
Contact us on: +30 69846.2259